

isotherm

® *by indel marine*

Marine Refrigerators and Boxes



Installation and operating instructions

indel
marine

General

Specially designed to operate in tough marine environments, Isotherm fridges are outstanding in both performance and reliability. Fitted with a fully hermetic, leak-free compressor, they offer the lowest possible power consumption and noise level. All models are extremely simple to install. They can withstand an angle of heel up to 30°, for a short time even more. To ensure that your Isotherm fridge operates as efficiently as possible, please follow these general guidelines:

- Unnecessary opening of the fridge door will increase power consumption.
- Good ventilation of the compressor and condenser unit will reduce power consumption.
- The electrical system should be in good condition. Inspect batteries and charging levels regularly. Always use a separate starter battery for the engine. Follow carefully the guidelines regarding electrical cable areas and fuse placements.
- Keep the inside of the fridge clean and dry. Remove any water that may collect on the shelf under the freezer compartment.
- Keep the door/lid slightly open to air the fridge when leaving the boat for any length of time. (Fig. 1 and 2)

Operation

Refrigerators and boxes with standard thermostat.

See separate instructions for ASU versions.

Temperature setting

The fridges/boxes are fitted with a manually operated, infinitely-variable thermostat. This is turned clockwise to reduce temperature and anti-clockwise to both increase temperature and activate the on-off switch at the end position. A certain spring resistance is recognized at the off position.

In most refrigerators, the thermostat knob is placed inside the refrigerator. The CR100 has the thermostat knob placed outside above the door. The build-in boxes and TB50 have the thermostat knob placed inside the refrigeration compartment.

The TB26 and 42 boxes have the thermostat regulation placed outside and also have separate on-off switches. The TB32 has an electronic thermostat, see separate instructions.

Defrosting

Defrosting shall be made when the frost layer is more than 4 mm thick. Set the thermostat in OFF position. Store the foodstuff and the liqued as cold as possible during the defrosting process. Do not use sharp metal tools to remove frost or ice. Do not re-start until the fridge/box is completely defrosted, cleaned and dried. Empty also the drip tray below the freezer compartment.

Maintenance

The Isotherm refrigeration systems have a fully hermetic closed cooling system and do not require any maintenance or refilling of refrigerant. The compressor is of domestic type and has a very high efficiency and an outstanding life-time. The fridge/box shall be left in the boat during the winter. (If the temperature is below freezing point, the compressor may not start). The maintenance is reduced to periodically, not less than a year, cleaning of the condenser from dust. Use a soft brush and no sharp tools. Keep the fridge/box inside clean. Use lukewarm water and a mild detergent for cleaning the inside. Put the door/lid, during not in operation periods, in its slightly open ventilation position. Release the catch on the door for this purpose with a coin or a small screwdriver. Take out the bulb from the internal light to avoid power consumption or switch off a main switch if there is one installed connected to the fridge power supply. (Fig. 1 and 2)

Battery voltage sensor

To protect the batteries from becoming completely discharged, a battery voltage sensor switches off the compressor automatically at the following levels:

System voltage	Cut-out	Cut-in
12	9.6	10.9
24	21.3	22.7

Safety instructions

When connected to shore power, ensure that the power supply is equipped with an earth safety automatic switch. **Danger!**

Never touch bare electrical wiring connected to the mains supply.

Danger!

Never connect battery charger direct to the refrigeration system.

Battery charger **must** be connected to the battery.

In addition to acid, a newly-charged battery contains explosive gas.

Danger!

Never cover the ventilation openings for the compressor unit.

Refrigerant may never be let out in the air.

Installation instructions

Many boats have a space which is intended for a fridge. The Isotherm Cruise fridge has been designed to suit the general dimensions normally used for this purpose.

The compressor should normally stand upright in the boat, but will operate at an angle of heel up to 30° and for short periods even more. The compressor on CR42 and 50 as well as on the BI40 is attached by its rear side. It can be removed so that it can be mounted by the side, from above or from below and is supplied with 1.5 m flexible piping. The pipe must be carefully bended to avoid breaks or other damages. Installation can be made even simpler by using the mounting rails, that are available as accessories.

The CR49, 65 and 195 have three side mounting frame mounted as standard which simplify the fastening of the fridge. It should always stand on its feet and fastened from the front in the mounting frame. Three side mounting frames are also available as an option for other models.

Build in boxes has to be well fastened and should be supported underneath. The compressor on BI41, 75 and 92 is attached by its bottom. It can be removed so that it can be mounted by the side or elsewhere and is supplied with flexible piping. The pipe must be carefully bended to avoid breaks or other damages.

The fridge doors are hinged on the right hand side as standard. They can be re-hinged to the other side by taking off the door, moving the upper door hinge pin to the other side and also changing side of the lower door hinge pin fittings. The door locking is re-positioned to the other side of the door upper frame. It is fastened with three screws. See fig. 3 & 4.

Ventilation

It is very important that the compressor/condenser unit is well ventilated and that cold air can enter at the bottom, pass behind the fridge and warm air can leave at the top in the area where it is mounted. The natural flow of air from below and upwards behind the fridge can be increased by arranging ventilation openings at the rear.

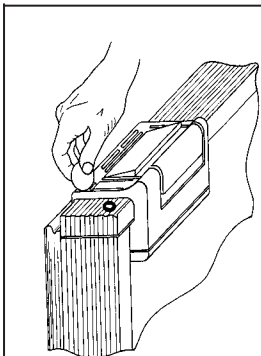

Fig. 1

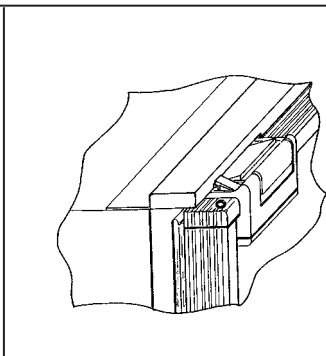

Fig. 2

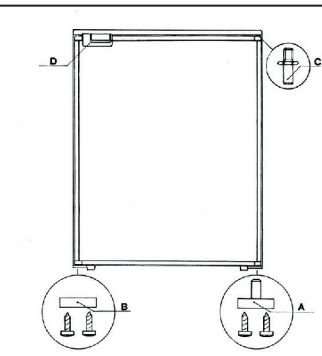

Fig. 3

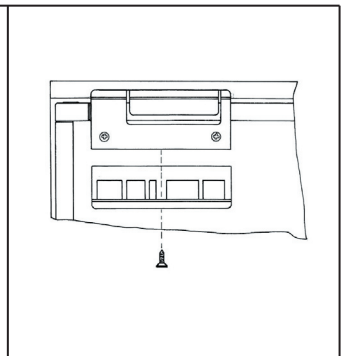

Fig. 4

Electrical connections/wiring

When connecting the fridge it is important that following points are considered:

* Always use cables of sufficient area. The area in the following table should be regarded as a minimum.

Cable area mm ²	Gauge	Max cable length in metres/ft 12 volt	Max cable length in metres/ft 24 volt
2.5	12	2.5 / 8	5 / 16
4	10	4 / 13	8 / 26
6	10	6 / 19	12 / 39

- * Always connect the fridge directly to the battery or to the battery main switch on the plus circuit. Do not connect it via the boats own control panel or other diversions as this can cause a voltage drop in the power supply. The system shall have a 15A fuse for 12 volt and a 7.5A in a 24 volt system. If a switch is fitted this should be of a minimum 20 A type.
- * Connect the red cable to the positive (+) terminal and the black to the negative (-) terminal. Always use proper type terminals or cable connectors of sufficient size for the cable size selected.
- * Do not connect the fridge direct to a battery charger. The battery charger must be connected to the battery.
- * See wiring diagrams.

Wiring diagram Cruise fridges and boxes

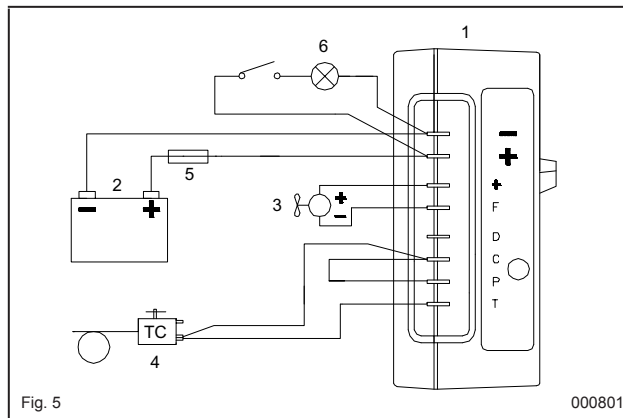

Fig. 5

000801

1. Electronic unit 12-24 volt
2. Battery
3. Fan
4. Thermostat
5. Fuse 15A-12V / 7.5A-24V
6. Inner light max 3W

Wiring diagram AC/DC Converter

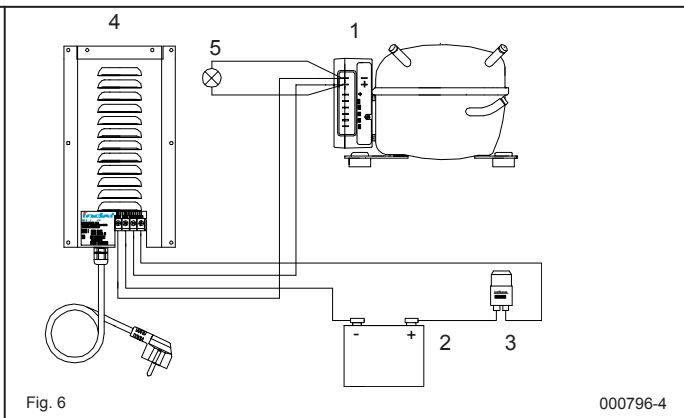

Fig. 6

000796-4

1. Electronic unit 12-24 volt
2. Battery
3. Fuse 15A-12V / 7.5A-24V
4. Converter 90-250VAC / 24VDC
5. Inner light 12/24 volt max 3 watt

Fault finding chart

Fault	Possible cause	Action
Fridge not cold. Compressor will not start.	No power supply. Battery in poor condition. Faulty thermostat. Faulty electronic unit.	Check that power is present at terminal box. check fuse. Internal light works? Check all terminal connections and cables. Inspect battery charging system. Check thermostat. Bridge T-C, if compressor starts, thermostat is faulty, replace. If compressor does not start, probably electronic unit is faulty. Exchange electronic unit.
Compressor makes only short start attempts.	Bad power supply, too low voltage or a voltage drop at start attempts. Discharged batteries.	Check cables and connections, possible verdigris, clean. Charge batteries, run the engine or connect battery charger. Voltage shall be above 11.0 volt at start attempts.
Compressor runs but no refrigeration generated.	Loss of refrigerant. Leakage in pipes or evaporator. Pipes blocked.	Mount service nipple on the compressor (refrigerators). Leak test, repair possible leak, evacuate and re-fill refrigerant. (All this to be made by refrigeration specialist)
Compressor runs long time but not generating enough cold.	Bad ventilation. Condenser too warm. Fan not working. Too much frost on evaporator. Door not closing well. Condenser blocked by dust.	Improve ventilation for compressor. Re-place fan. Defrost. Check door position and door seal. Clean condenser.

Technical data

Voltage:	12/24 volt
Power consumption:	2.5 - 6 A (depending on model and compressor speed setting)
Average power consumption:	0.6 - 2.5 A (depending on model) Freezer models; 2 - 2.5 times higher average power consumption
Compressor:	Danfoss BD35F alt. BD50F (depending on model)
Refrigerant:	R134a (filled amount written on type sticker inside fridge or outside box housing)
Fuse:	12 volt - 15 A, 24 volt - 7.5 A
Battery protection:	Cut-out at 9.6 volt (21.3), cut-in at 10.9 volt (22.7)

Isotherm refrigerators and freezers fulfills EMC directives, CE-marked



2

indel
marine
IT-61019 S. Agata Feltria (PU) - Italy
Phone +39 0541 848030
Fax +39 0541 848563
info@indelmachine.com

www.indelmachine.com
www.isootherm.com

indel
marine USA corp.
5300 NW 12th Avenue unit #2
Fort Lauderdale, FL 33309, USA
Phone: +1 954 772 8355, +1 800 422 9711,
Fax: +1 954 772 3839
info@indelmachineusa.com www.indelmachineusa.com